

Arec

# LS-860N Media Station



- Versatile Inputs: HDMI\*4, Line in\*4, and IP Streaming Channels\*4
- NDI|HX Support for NDI-based Video Production
- Support SRT Streaming Protocol
- All-in-One Device to Offer Up to 4 Full HD Video Sources Capturing, Mixing, Switching, Recording and Live Streaming
- Touch-Friendly Graphical User Interface Makes Live Production Easier



USB Numeric Keypad

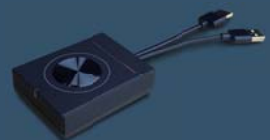

ARECast

NDI<sup>®</sup>|HX

This product complies with the NDI|HX, a technology of NewTek, Inc.

# Main Features

## Capture Up to 4 Video Sources at Once with Versatile Inputs

Via HDMI\*4 and IP streaming inputs, AREC LS-860N Media Station supports up to 4 Full HD 1080p video sources capturing, mixing, switching, recording and live streaming. LS-860N is compatible with network-based H.264 RTMP/ RTP/ RTSP (video only) and NDI|HX sources. With LS-860N, users can choose 1 mixed video plus 4 individual videos recording for flexible use.



## Intuitive and Versatile Control Options

AREC Online Director supports a wide range of control options, including Web Browser (Chrome, Edge, IE), Software Application (Windows, Mac OS), Touch-Friendly Graphical User Interface, and Mini Controller from Mobile Device. All-new Mini Controller and Graphical User Interface design bring easier and faster control than ever. Control buttons on the front of LS-860N are also provided.

\*The on-screen GUI supports mouse device control through USB connection.



On-screen GUI & USB Interface\*



Web/ SW-based Online Director



Mini Controller from Mobile Device

## Broadcast Your Mixed Video

LS-860N can stream mixed video to up to 2 platforms simultaneously, such as YouTube, Facebook, and other live broadcasting websites.



## Real-Time Assistant in Video Making

With AREC Online Director, LS-860N allows users to be in control of their video recording/streaming in real-time. It makes users easily switch and mix between sources, add or remove logos, backgrounds and overlay graphics (titles) for live production. LS-860N supports overlay PNG images with transparent, opaque, and in between.

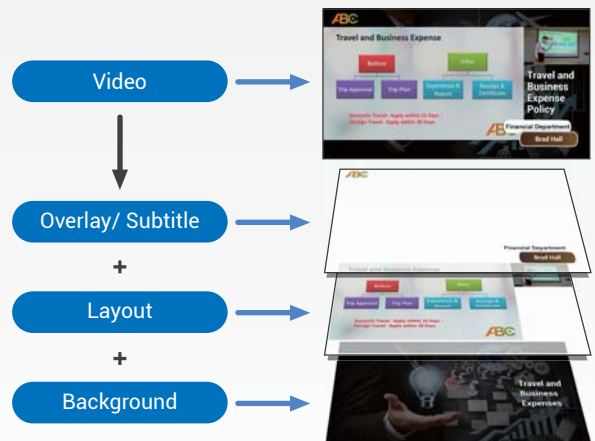

## AREC Video Manager : Videos with Just One Click

With the built-in Video Manager, administrators or teachers can manage videos saved in the local Media Station remotely. They can download, upload or delete a video file, and edit video information. With available APIs, all of the video content, metadata, and thumbnail can be delivered seamlessly for third party integration.

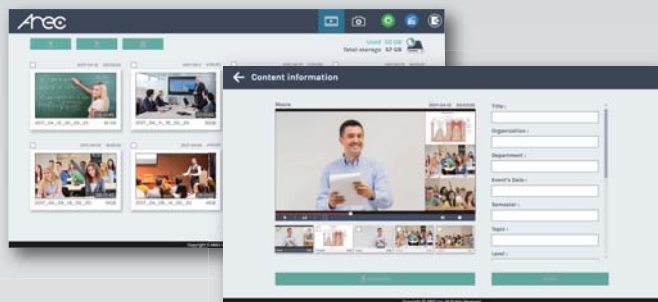

## Backup & Upload Your Recordings

With internal 2TB hard drive, LS-860N can save hundreds of hours recording videos. To increase security, LS-860N can automatically backup or upload recordings to AREC Media-Center, FTP, SFTP, NAS, Opencast, Kaltura, Panopto and so on.



SATA 2TB HDD



OPENCAST Panopto KALTURA  
FTP/ SFTP Backup



## Product Interface

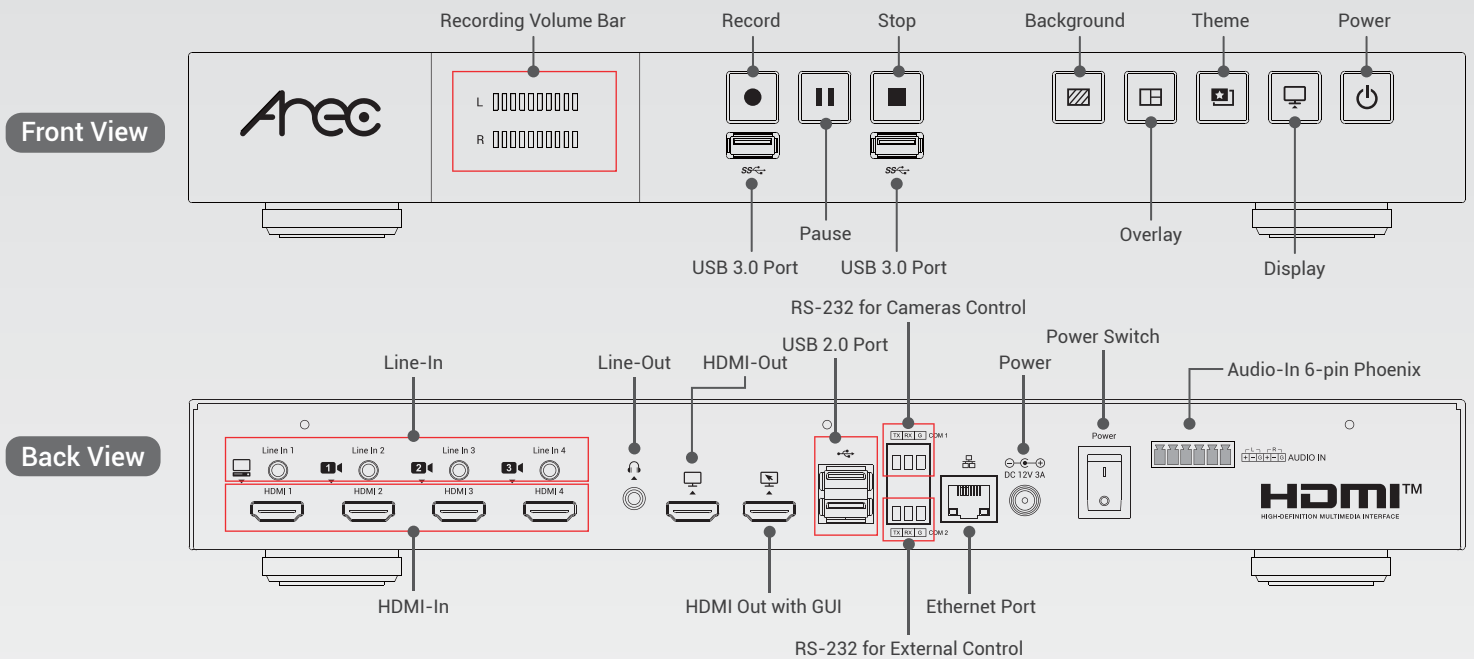

## On-Screen Graphical User Interface

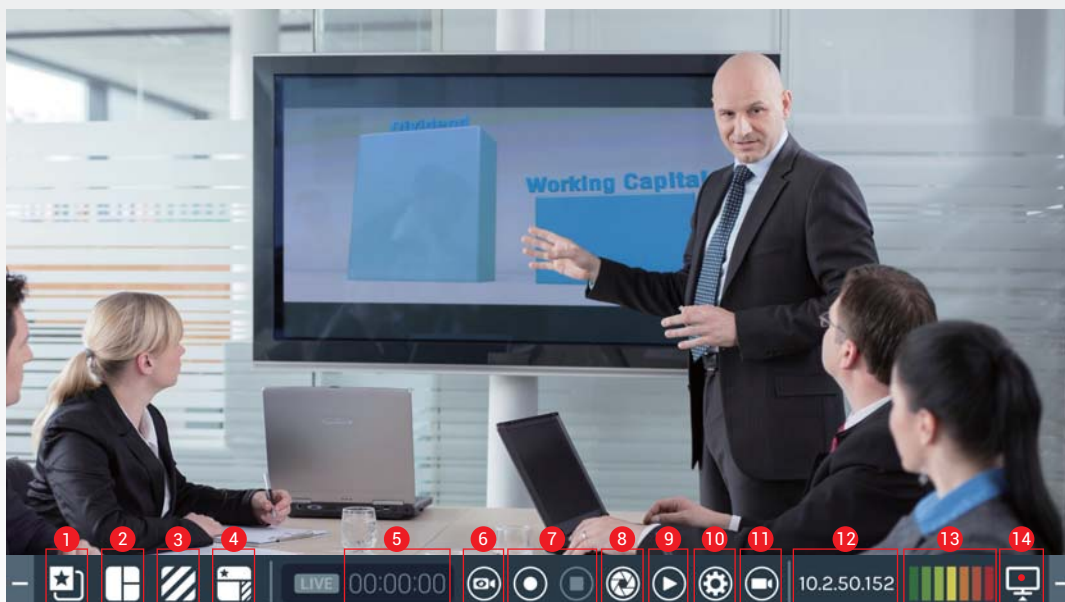

- 1 Overlay Images
- 2 Recording Layouts
- 3 Background
- 4 Custom Theme
- 5 Timer
- 6 Start / Stop Streaming
- 7 Start / Stop Recording
- 8 Snapshot
- 9 Playback Video
- 10 Setting
- 11 Camera Control
- 12 LS-860N IP Address
- 13 Audio Volumn Bar
- 14 Display Switch

\* The on-screen GUI supports mouse device control through USB connection.



# Specifications

Model Name	AREC LS-860N Media Station
Input Connection	
Video Input Interfaces	HDMI*4 RJ-45*1 (supports IP streaming: up to 4 channels; wireless projection for 1 channel)
	Note: 1. Supports network protocol: H.264 RTMP/ RTP/ RTSP, NDI HX and ARECast 2. Supports AREC network cameras, compatible 3rd party network cameras, encoders, streaming sources via IP streaming and ARECast
Max. Video-In channels	Maximum 4 channel synchronized recording
Resolution	Max. 1080p60
Audio-in Channels	mm Stereo*4; HDMI*4 Balanced audio-in with a 6-pin Phoenix connector RJ-45*1 (supports IP streaming: up to 4 channels)
	Note: Supports network protocol: H.264 RTMP/ RTP and NDI HX
Audio Mixing	Mix up to 5 audio input sources into 1
Video Processing	
Compression	H.264/ AVC/ NDI HX
Frame Rate	Max. 60fps
Bit Rate	300Kbps~16Mbps
Resolution	Max. 1080p (640x360 ~ 1920x1080)
Audio Processing	
Compression	AAC-LC
Bit Rate	80Kbps~320Kbps
Video / Audio Outputs	
Video Outputs	1x HDMI preview port (preview recording with on-screen GUI) 1x HDMI display port (inputs display or multi-source monitoring) 6x H.264/AVC digital video over Ethernet NDI HX digital video over Ethernet
Output Resolution	1080p60
Audio Outputs	1x 3.5mm Stereo Line out 2x HDMI
Streaming	
Streaming Delay	1 sec.
Compatible Streaming Input Protocols	RTSP, RTP, RTMP, NDI HX
Streaming Output Protocols	RTP, RTMP (RTMPS), RTSP, NDI HX, SRT
	Note: 1. users can choose output options from RTP or RTMP(RTMPS) 2. RTP: MPEG2-TS over RTP unicast; MPEG2-TS over RTP multicast 3. RTSP (TCP/ UDP): Max 6 clients RTSP streaming can only pull from URL
Storage, Backup, and Compatibility	
Built-in Local Storage	2TB 2.5" SATA III Hard Drive
External Storage	Supports USB drive recording through the front port. NAS storage is also supported
Locally Stored File Format	MP4
Backup	FTP/ SFTP
Third-Party Video Management System	Compatible with Opencast, Panopto and Kaltura
Live Broadcasting	
Live Broadcast to CDN or Stream Server	Mixed video: support RTMP (RTMPS) protocol. Stream up to 2 platforms simultaneously
Video Information Editing	
Post Video Info Editing	Yes, through Video Manager web page
Video Info Adding	Video info will be added on video file name automatically while file output or uploading

Recording	
Recording Modes	Mixed mode, 1 mixed + 4 individual original sources
	Note: For individual source recording, the audio can be selected by mixed or individual original source
Scheduled Recording	Yes, supports iCalendar format (.ics file), such as google calendar
Recording Layouts	34 layouts for pre-defined, including full screen/ picture-in-picture/ picture-by-picture/ multi-channel split screen
Bookmark	Automatic and manual bookmark insertion
Background Images	Multiple for user-defined
On-Screen Overlay Images	Multiple for user-defined, support PNG format with transparent, opaque, and in between
Custom Themes	Multiple for user-defined, setting from web-based back stage
Controls of LS-860N and Camera	
Touch Interface	Through recommended touch screen and interactive projector
Mouse Device and Numeric Keypad	Through USB interface connection
Video Switcher	Yes, through AREC Online Director (web-based or desktop applications) or on-screen GUI for manual controls
Mini Controller	Through mobile web browser and wireless connection for manual controls
External Control	Yes, supports RS-232 interface port
Control Button	Yes, at the front of the media station
Video Manager Platform	Built-in video manager platform: through web-based control interface
Group Management	Yes, through ARECloud
Camera Control	VISCA / PELCO-D / PELCO-P / VISCA over IP/ ONVIF profile S / NDI@
General Information	
Operation System	Embedded Linux system
Power Supply	12V / 3.34A
Temperature / Humidity	0~40°C / 90%
Dimensions	366mm(L) x 182mm(W) x 53mm(H)
Weight	2.125 kg (4.68 lbs)
Language	SC/ TC/ English/ Russian/ Spanish/ Czech/ Korean/ Latvian/ German/ Estonian
Accessories	Power adapter/ quick guide/ ear mounts/ USB Numeric Keypad/ ARECast wireless projection button



AREC Inc. | [www.arec.com](http://www.arec.com) | [sales@arec.com](mailto:sales@arec.com)  
 Headquarters: Taipei, Taiwan Address: 3F, No. 367, Sec.2, Wenhua RD.,  
 Banqiao Dist., New Taipei City 220, Taiwan (R.O.C)  
 TEL: +886-2-8259-5060

Exclusive Representative in Europe, Africa, Latin America and CIS Countries  
 ADENA Limited | [www.a-dena.com](http://www.a-dena.com)  
 E-MAIL: [yakov@a-dena.com](mailto:yakov@a-dena.com)  
 TEL: +886-2-8712-1882

AREC reserves the right to modify product specifications without prior notice.